

EasyCut Straight 24 Saw



The EasyCut Straight 24 (ECS24) is an optional upcut saw with a 24" blade and is great for Wall and EWP cutting.

Features

- Cuts up to (4) 2x boards stacked high
- Material sizes: 2x4 to 4x16; 6x14; and 8x8, including EWP
- Depending on other options chosen and number of workers per shift
 - Up to 20,000 board feet cut per shift for wall parts
 - Up to 14,000 linear feet per shift for EWP

Compatible with: Walls, Floors, EWP, Big Timbers

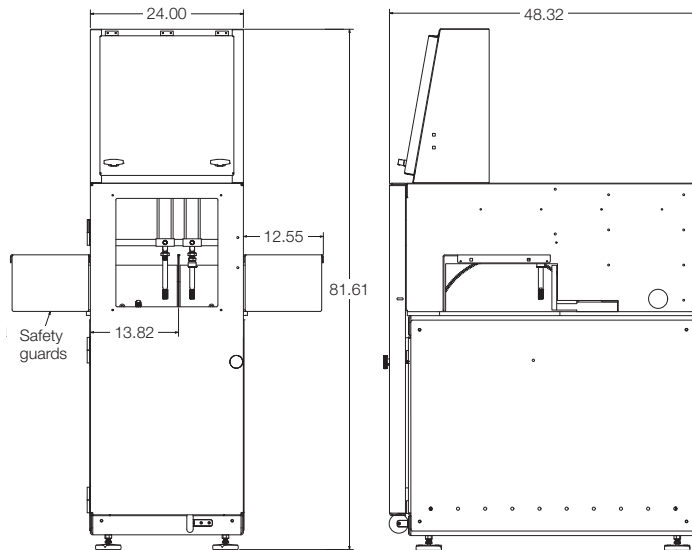
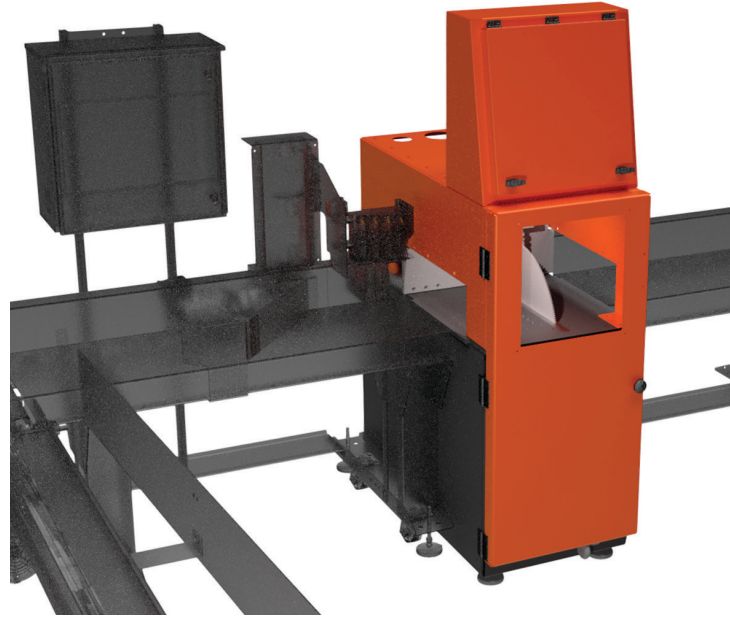

Capabilities

Blade Size	24"
Cut Angles	90° only

Specifications

Voltage	3-phase Voltage 230-240 or 460-480
Air Pressure	80 psi
Air Volume	Varies depending on cutting factors. Recommended minimum of 10 cfm.
Lubrication	Needed for 6 high-speed bearings
Motor	10 hp motor
Dust Collection	<ul style="list-style-type: none"> • (1) 4" port and (2) 3" port • See easyframesaw.com for recommended dust collection • Dust collector not provided
Minimum Suction Required	1900 cfm

Let's continue the conversation. Email us at sales@easyframesaw.com or contact your Simpson Strong-Tie Building Technology Representative at (833) 327-9376 to find the right equipment solution for your business.

(833) 327-9376
strongtie.com